

## Boiler-collector connection kits

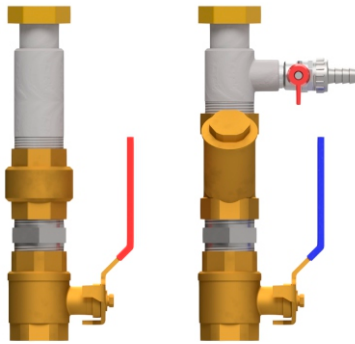

Connection set have been designed to facilitate the connection of Crystal boilers to the collector.

**Technical data:**

Material: **steel, brass, cast iron**

Maximum pressure: **6 bar**

Maximum temperature: **90°C**

Connection:

boiler side: **1" nut - for 42 kW, 59 kW boilers**

**1 1/4" nut - for 80 kW, 100 kW boilers**

installation side: **1" F - for 42 kW, 59 kW boilers**

**1 1/4" F - for 80 kW, 100 kW boilers**

Type	Catalog number
Connection set - boiler - collector 1" for boilers Crystal 42kW, 59kW	T 9260 14 01 00
Connection set - boiler - collector 1 1/4" for boilers Crystal 80kW, 100kW	T 9260 14 02 00

### Connection **1"** for boilers **Crystal 42kW, 59kW**

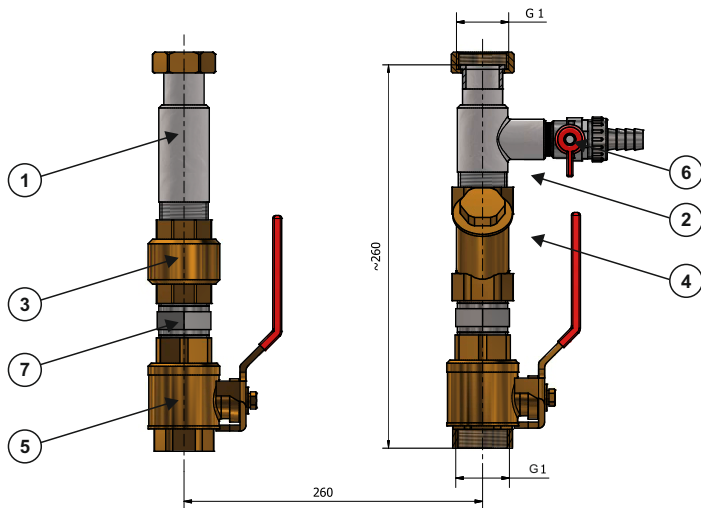

**Set contains:**

1. Steel connector with 1" nut
2. Steel connector with 1" nut and 1/2" socket
3. Non-return valve DN 25
4. Diagonal filter DN 25
5. Ball valve DN 25
6. Drain valve G 1/2"
7. Nipple 1"

### Connection **1 1/4"** for boilers **Crystal 80kW, 100kW**

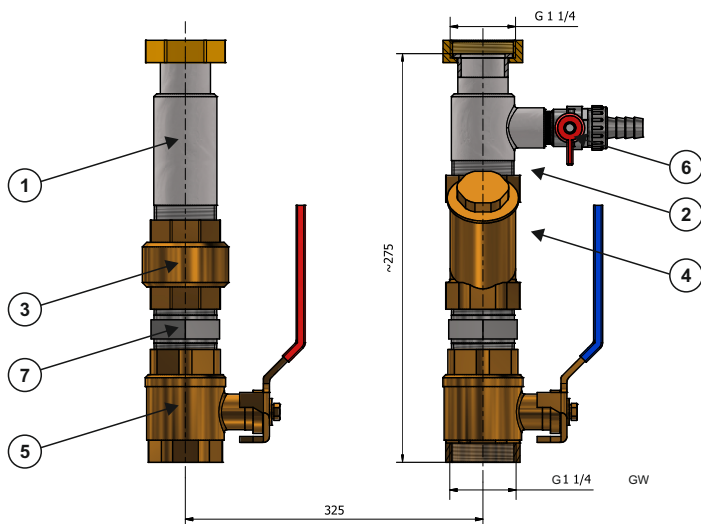

**Set contains:**

1. Steel connector with 1 1/4" nut
2. Steel connector with 1 1/4" nut and 1/2" socket
3. Non-return valve DN 32
4. Diagonal filter DN 32
5. Ball valve DN 32
6. Drain valve G 1/2"
7. Cast iron nipple 1 1/4"

Connection kits are not installed by the manufacturer. The elements of the set should be assembled at the place of installation of the connections according to the pattern presented above.

# Warranty card



## Terms of warranty

1. Termet S.A., hereinafter referred to as the Guarantor, grants the Buyer a guarantee for the proper operation of the device described in detail in the Warranty Card. The warranty card is recognized valid if it has legible and correctly filled in boxes containing the date of sale, date of installation, seal and signature of the Seller.
2. The warranty period for the device is 24 months from the date of sale, but not longer than 30 months from the date of introduction to distribution. The warranty is valid only on the territory of the Republic of Poland.
3. The warranty covers the removal of all kinds of technical defects of the equipment, which are the result of its normal operation in accordance with the instruction manual and will be revealed during its validity period. The warranty does not apply to consumables or other accessories. Under the warranty granted, the Guarantor is not responsible for the loss of expected benefits and costs incurred by the Purchaser resulting from the use or inability to use this equipment.
4. In order to exercise the warranty rights, it is required to deliver the defective equipment together with this warranty to the point where it was purchased or to another place indicated by the Guarantor.
5. The condition for accepting a complaint during the warranty period is to deliver the equipment in a complete state with a valid warranty card, a copy of the proof of purchase, and a detailed description of the fault prepared by the Buyer. To process the complaint, it is also necessary to provide basic data identifying the Buyer, his exact address, contact telephone number, email address.
6. The claimant is obliged to deliver the equipment in a package secured with adhesive tape. In the absence of the factory packaging, the complained equipment should be delivered for repair by the Buyer in a way that ensures safe transport. In the case of improper packaging, the Buyer is responsible for the risk of damage that may result in transport. The costs related to the provision of proper, safe packaging shall be borne by the Purchaser.
7. Defects revealed during the warranty period will be removed by the Guarantor free of charge. The choice of the method of fulfilling the obligations arising from the warranty granted to the Buyer belongs to the Guarantor, who may remove the defect by repairing or replacing the damaged part, or by replacing the device in its entirety. The replaced device and defective components become the property of the Guarantor.
8. The warranty does not cover venting the installation and other activities provided for in the instruction manual, which the user is obliged to perform on his own and at his own expense.
9. In the event of an unjustified complaint, the Guarantor may charge the Buyer with the costs of the expertise, restoring the functionality of the product and the costs of transporting the product. An unjustified complaint is considered to be the return of functional equipment to the service address or, in the event of damage due to the reasons indicated in point 15, 16, 17, 18 below.
10. In the event of replacement of the equipment with a new one, the equivalent of the parts missing or damaged by the Purchaser and the cost of their replacement shall be deducted.
11. The guarantor will take steps to ensure that the repair is made within 14 days from the date of delivery of the device to the service. In justified cases, this period may be extended, but the Guarantor will exercise due diligence to remove the defect as soon as possible.
12. If the complaint is not accepted, the Guarantor shall notify the Buyer about it within 14 days from the date of delivery of the device to the service.
13. The Guarantor is not liable for non-performance of obligations under the guarantee due to unforeseeable circumstances beyond his control, such as lightning or power surges, etc.
14. The Guarantor is responsible for defects resulting only from reasons inherent in the sold product. The warranty does not cover damage caused after its sale for other reasons, in particular:
  - mechanical, thermal, chemical damages and improper operation of the product resulting from these damages and defects caused by them,
  - damage resulting from non-compliance with the typical or specified in the operating instructions rules for using the product, using the product contrary to its intended use and other damage caused by the Buyer,
  - damage resulting from damage to the system in which the equipment was installed or used,
  - damage resulting from failure to perform activities that the user is obliged to perform in accordance with the operating instructions, e.g. periodic cleaning, maintenance, adjustment, etc.
  - damage and defects caused in transport,
  - damage and defects caused by random events, independent of the operating conditions (fire, flood, incorrect power supply voltage, etc.).
  - claims for technical parameters of the product, provided that they are consistent with the manufacturer's data.
15. The buyer loses the warranty rights in the event of:
  - removal or obliteration of product serial numbers,
  - any attempts at repairs, modifications or structural changes made by persons not authorized by the Guarantor,
  - loss of the warranty card or making changes and deletions in it by unauthorized persons.
  - using non-original parts or materials.
16. The warranty does not cover consumables and elements subject to natural wear and tear (e.g. seals, etc.).
17. The product delivered to the service should be clean. The service technician may refuse to accept a dirty, contaminated product or clean it at the buyer's expense.
18. Products are maintenance free. They should be installed, commissioned, operated and dismantled only by suitably qualified and trained personnel. Changes and modifications made by unauthorized persons may cause hazards and are prohibited for safety reasons.
19. Warranty for the product sold - consumer goods do not exclude, limit or suspend the buyer's rights resulting from the non-compliance of the goods with the contract.
20. The rights under this warranty are vested only in the Buyer indicated in the warranty document, who confirmed acceptance of its terms by signing. Warranty rights are not transferable to subsequent buyers.
21. In matters not covered by the terms of this Guarantee Card, the relevant provisions of Polish law shall apply.

Between 7 am and 3 pm (Mon-Fri) information about failures can be reported by phone (74) 85 60 801 or by e-mail: [serwis@termet.com.pl](mailto:serwis@termet.com.pl)

The seller checked in my presence the correct operation of the product, its completeness and stated that the equipment is not burdened with a manufacturing defect. The equipment is considered to be burdened with a manufacturing defect if it does not fulfill the functions specified by the manufacturer in the instruction manual and it is not possible to use it as intended, and the reason for the failure results from the internal properties of the equipment. I have read and accept the terms of this warranty. I consent to the processing of my personal data for the purposes of the warranty repair.

.....  
First name, surname and signature of the Buyer:

Connection set - boiler - collector 1" for boilers Crystal 42kW, 59kW  
Cod.: T 9260 14 01 00

Connection set - boiler - collector 1 1/4" for boilers Crystal 80kW, 100kW  
Cod.: T 9260 14 02 00

.....  
Date of introduction to sale:

Date of installation and seal and signature of the installer: